



**Installation and Operation Manual
for
TVCD606**



Please read the operation manual carefully
before installing and using this unit

I. Points for Attention

1. Before installing the omni bearing intelligent unit, please read the operation manual carefully.
2. The camera takes power supply of DC12V/1.2A. You should assure that the power supply of the product has an input voltage with load about 12V rather than a unload voltage of 12V, otherwise the camera couldn't work normally.
3. During the process of transportation, storage and installation, the dome should be avoided of incorrect operations such as heavy pressing, strong vibration etc. which can cause damage of product as there are sophisticated optical and electronic devices inside the machine.
4. Do not attempt to disassemble the camera. In order to prevent electric shock, do not remove screws or covers. There are no user serviceable parts inside and only qualified personnel are to service the unit

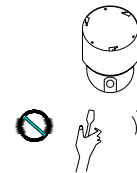

5. Always follow all electrical standards for safety when it is in operation. Adopt the particular power supply, which is provided with the dome. RS-485 and video signal should keep enough distance with high voltage equipments and cables when they are in transmission. Precautions for anti-lightning and anti-surgings should be taken if necessary.
6. The product should be indoor installed and operated to avoid rain and moisture. Do not use it in wet places. If outdoor installation is needed, the closed protect cover should be used and it is absolutely prohibited to use it in open air independently.



7. Do not operate it in case temperature, humidity and power supply are beyond the limited stipulations.
8. Do not let the video camera aim at the sun or the object with extreme light whatsoever it is switched on or not. Do not let the video camera aim at or monitor bright and standstill object for a long time.
9. Do not use aggressive detergent to clean the main body of the video camera. Wipe dirt with dry cloth. If needed, mild detergent can be used suitably.
10. Operate the intelligent high-speed spherical video camera with great care to avoid shock or vibration. It operate incorrectly, machine could be damaged.
11. Install the video camera in the place where endurance should be enough large.
12. Should be dust on the lens, you should wipe it with special lens tissue.

II. Description of Functions

The dome camera is a hi-tech CCTV product, which incorporates color TV, omni bearing dome P/T and multifunctional decoder into a whole. It can largely reduce connection and installation processes of components in the system, rise up reliability of the system and facilitate installation and maintenance. Therefore it has advantages of beautiful appearance, compact structure and easy operation.

1. Integrated Multi-Protocol Decoder

- a. With built-up decoder and integrated multi-protocol, it can integrate 16 kinds of communication protocols in maximum. As its baud rate of communication can be adjusted, it is compatible with main domestic and foreign systems by easy setting inside the spherical camera, so it has stronger versatility.
- b. RS485 serial control: addresses of the dome camera 1-1023.

2. Integrated Omni bearing dome P/T

- a. Turning 360° horizontally and continuously with unlimited positions. PAN speed range:0~15rad/s (constant speed dome PAN: 15rad/s); turning 0~90° vertically with a speed 0~15rad /s(constant speed dome TILT: 15rad/s).
- b. Running stably at low speed with super lower noise. Pictures have no shaking.
- c. the location precision up to $\pm 0.2^\circ$.

3. High Intelligent Degree

- a. Support the dome camera to scan horizontally between two points and scan speed can be modified.
- b. Data can be stored with powerless memory.

4. Newly-Added Functions

- a. Flexible and Convenient Application: there are many communication protocols integrated inside the spherical camera and the baud rates can be selected from 24000 bps to 19200 bps.

5. Selectable Optical Zoom Range of Camera

Times of Optical Zooming	Focus Range	Lowest Illuminance
16x	f3.9-f6.3 mm	1 Lux (F1.4)
18x	f4.1-f73.8 mm	1 Lux (common type) / 0.01 Lux (day & night type)
22x	f4-f88 mm	0.2 Lux (F1.6 1/3s)
23x	f3.6-f82.8 mm	1 Lux (Common type) / 0.01 Lux (day & night type)
25x	f3.6-f90 mm	1 Lux (Common type) / 0.01 Lux (day & night type)

III. Settings of Special Camera

Before installing the spherical camera, please confirm the communication protocol and baud rate the master controller in the system uses, then set the coding switches on the back of the camera to be identical with that of the system in which SW1 is for address of the spherical camera and SW2 is for communication protocol and baud rate (see attached tables 1,2 and 3).

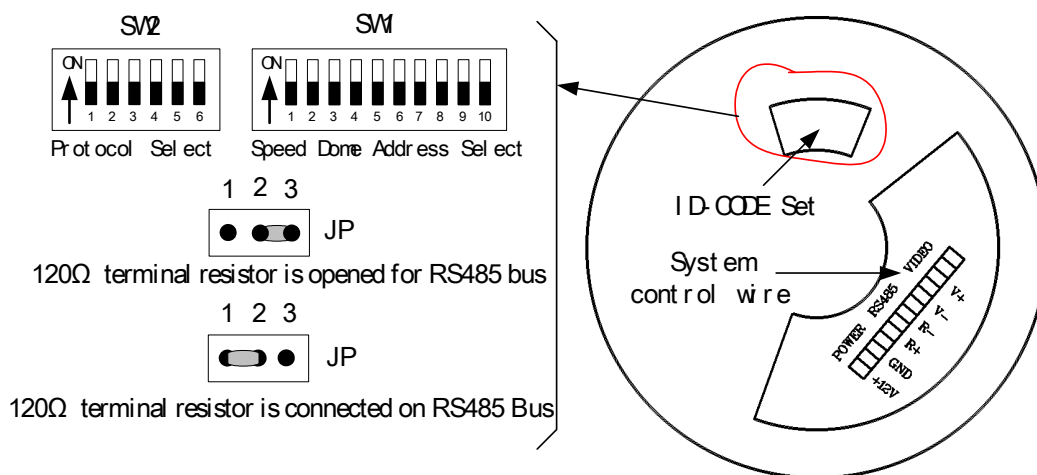

JP1 is jumper for the terminal resistor

JP1 is the 120 Ω terminal resistor for RS485 Bus. When short-circuit terminal is set between “1-2”, the 120 Ω terminal resistor is opened while it is set between “2-3”, the resistor is connected. Take care that on RS 485 Bus only one farthest spherical camera has the terminal resistor connected while other devices should have their terminal resistors opened.

- **Settings of Addresses of dome Cameras**

Dome Address	States of Coding Switches										
	DIP-1	DIP-2	DIP-3	DIP-4	DIP-5	DIP-6	DIP-7	DIP-8	DIP-9	DIP-10	
1	ON	OFF	OFF	OFF	OFF	OFF	OFF	OFF	OFF	OFF	
2	OFF	ON	OFF	OFF	OFF	OFF	OFF	OFF	OFF	OFF	
3	ON	ON	OFF	OFF	OFF	OFF	OFF	OFF	OFF	OFF	
4	OFF	OFF	ON	OFF	OFF	OFF	OFF	OFF	OFF	OFF	
5	ON	OFF	ON	OFF	OFF	OFF	OFF	OFF	OFF	OFF	
6	OFF	ON	ON	OFF	OFF	OFF	OFF	OFF	OFF	OFF	
7	ON	ON	ON	OFF	OFF	OFF	OFF	OFF	OFF	OFF	
8	OFF	OFF	OFF	ON	OFF	OFF	OFF	OFF	OFF	OFF	
9	ON	OFF	OFF	ON	OFF	OFF	OFF	OFF	OFF	OFF	
10	OFF	ON	OFF	ON	OFF	OFF	OFF	OFF	OFF	OFF	
11	ON	ON	OFF	ON	OFF	OFF	OFF	OFF	OFF	OFF	
12	OFF	OFF	ON	ON	OFF	OFF	OFF	OFF	OFF	OFF	
13	ON	OFF	ON	ON	OFF	OFF	OFF	OFF	OFF	OFF	
14	OFF	ON	ON	ON	OFF	OFF	OFF	OFF	OFF	OFF	
15	ON	ON	ON	ON	OFF	OFF	OFF	OFF	OFF	OFF	
16	OFF	OFF	OFF	OFF	ON	OFF	OFF	OFF	OFF	OFF	
17	ON	OFF	OFF	OFF	ON	OFF	OFF	OFF	OFF	OFF	
18	OFF	ON	OFF	OFF	ON	OFF	OFF	OFF	OFF	OFF	
...	
1023	ON	ON	ON	ON	ON	ON	ON	ON	ON	ON	

Table 1

For Example:

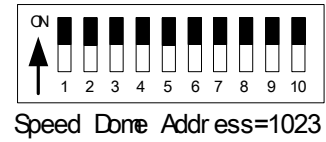
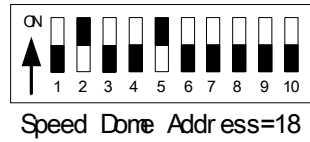
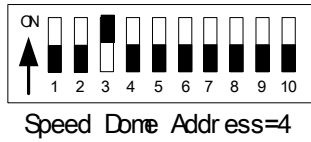
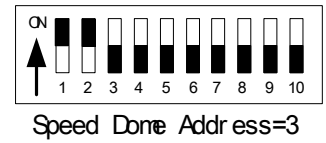
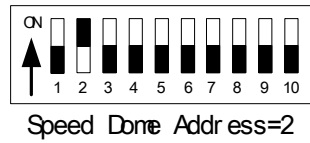
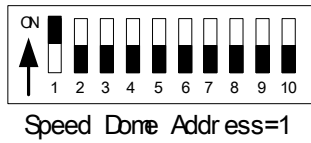

Notes:

1. Addresses of the dome cameras are denoted by binary code system. ON means “1” while OFF means “0”.
 2. Above coded addresses are only from no.1 to no.20. The codes of addresses from no.21 to no.1023 can be deduced by analogue.
 3. The range of addresses of the spherical cameras is from 1 to 1023.
- Settings of communication protocol of the dome camera (DIP1-DIP4 of SW2) and its default baud rate (DIP5-DIP6 of SW2). In case the default baud rate of the dome camera is not in accordance with that of the controller, please reset it as per the Table 3 (● means the protocol has been done).

Type of Protocols	Selection of Protocols				Normal Baud Rate		Integrated Protocol
	DIP-1	DIP-2	DIP-3	DIP-4	DIP-5	DIP-6	
Minking A01	OFF	OFF	OFF	OFF	ON	OFF	●
Minking B01	ON	OFF	OFF	OFF	OFF	ON	●
Santachi	OFF	ON	OFF	OFF	OFF	ON	●
PELCO-D	ON	ON	OFF	OFF	OFF	OFF	●
PELCO-P/4800	OFF	OFF	ON	OFF	ON	OFF	●
PELCO-P/9600					OFF	ON	
PANASONIC	ON	OFF	ON	OFF	OFF	ON	○
Longcomity	OFF	ON	ON	OFF	OFF	ON	●
HUNDA600	ON	ON	ON	OFF	OFF	ON	●
LILIN	OFF	OFF	OFF	ON	ON	OFF	○
VICON	ON	OFF	OFF	ON	ON	OFF	○
MOLYNX	OFF	ON	OFF	ON	OFF	ON	○
KALATEL	ON	ON	OFF	ON	ON	OFF	○
VCL	OFF	OFF	ON	ON	OFF	ON	○
DAIWA	ON	OFF	ON	ON	OFF	ON	○
ALEC	OFF	ON	ON	ON	OFF	ON	○
Utralk	ON	ON	ON	ON	OFF	ON	○

Table 2

Protocols mentioned above are suitable for the dome camera. Among them “Santachi”, “ PELCO-D” and “PELCO-P” have no corresponding orders for some special functions in the protocols. In order to control some special functions of the spherical camera, we make some functional transformation upon some common orders. Normally we take “Call Preset Position / Set Preset position” to transform, and contents of order transformation are listed below.

Number of N Value	Control Object	Definition of Keypad Operation	
		Call No. N Preset Point	Set No. N Preset Point
51	Supplementary Control of dome	Start Scan (low Speed)	Start Patrol
52		Start Scan (middle Speed)	Set Start Position of Scan
53		Start Scan (high Speed)	Set End Position of Scan
54	Power Supply of Camera	Power Supply On	Power Supply Off
55	BLC	On	Off
56	Zero Illuminance	On	Off
57	Screen Display *	On	Off
58	D-Zoom	On	Off
59	Focus	Automatic	Manual
60	Iris	Automatic	Manual
61	Mode of White Balance *	Automatic	Manual
62		Interior	Exterior
63		ATW	One Push WB
64			

Notes:

1. Those Items with “*” have memory function even the dome is switched off.
 2. For those cameras with “menu”, you can use “Screen Display ON” to control the Menu ON/OFF, and use “Screen Display OFF” to control Screen Display ON/OFF.
 3. For those cameras which have no “Zero Illuminance” or the function of “Zero Illuminance” is automatically switched without control, then above “Zero Illuminance” is invalid.
 4. Notes to “Patrol” Function of the dome camera:
 - ① Automatically scan from no.1 to no.16 preset points one by one. If some points do not have been preset or are cleared out after presetting, they will be bypassed when patrol is carrying out.
 - ② The dwelling time between to preset points is 4 seconds.
 - ③ The “Patrol” function of the dome camera can be carried out by presetting no.51 position.
 5. Notes to “Scan(auto pan)” Function of the dome camera:
 - ① The dome camera makes automatic scan between two specified positions.
 - ② The speeds of scan are divided into three levels. You can call no. 51, 52 and 53 preset position to start scan at speed of 1.5°/ sec, 5°/ sec and 10°/ sec separately.
 - ③ The dwelling time between the “Start Point” and “End Point” of scan is 3 seconds.
 6. All notes mentioned above are supplementary descriptions under high speed. All original operations of the control system are unchanged.
- Settings of Communication Baud Rate of the dome Camera

Coding Switch	1	2	3	4	5	6
2400 bps					OFF	OFF
4800 bps					ON	OFF
9600 bps					OFF	ON
19200 bps					ON	ON

IV. Steps of Installation

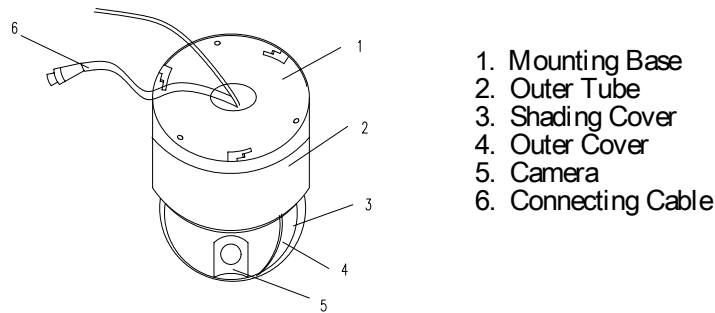

Dimension Drawing

1. Carefully read the operation manual and the points for attention.
2. Carefully set the communication code, baud rate and address of the dome camera and make confirmation they are correct.
3. Take out the plug of the dome camera and connect external power supply, RS485 and video wires as per marks on the plug. Take care that the power supply of the dome camera is DC12V/1.2A and adopt the particular power supply which is provided with the dome camera.

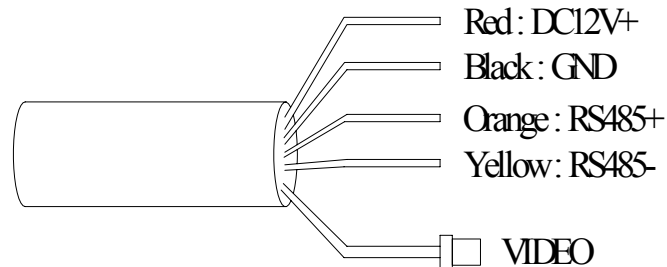

4. Take out the mounting base from the spherical camera, thread the connecting wire from behind through the central hole of the base. Fix the base by three screws on the ceiling as per the drawing, and connect the wire with the ball. Aim the latch in the ball with the notch on the base as per the drawing, and mount the ball upward to the position and turn it clockwise until the spring sheet on the base takes effect. In case the wire could not come out from behind the ceiling, you can open a hole on the edge of the casing for running of the wire.

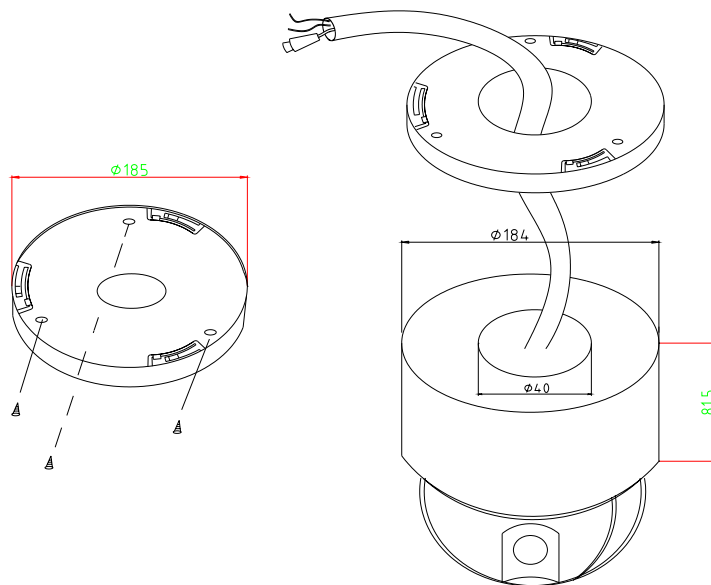

Installation Drawing

V. Main Technical Data

Specifications	Image Inductor	1/4" Color CCD
	Effective Pixels	752H×582V (440000pixels) PAL
	Synchronous System	Internal Synchronization
	VF Output	Compound Signal 1.0Vp-p/75 Ω
	White Balance	Automatic/Manual
	Power Supply	DC12V±10% 1.2A
	Power Consumption	12VA
	Weight	2Kg
	Mounting Style	Ceiling or ceiling hanging style
	Relative humidity	10-75% (under no condensing)
	Operation Temperature	0°C~40°C
Camera Function	Scan System	15.625KHz(H) 50Hz (V)
	Horizontal Resolution	480 TV lines
	Signal / Noise ratio	Larger than 48 db
	Electronic Shutter	1/3~1/10000 seconds
	Lowest Temperature	1Lux, AGC ON
Lens Data	Zooming Range	18×Optical and 12×Digital

	Iris	Automatic/Manual
	Focus	Automatic/Manual
Basic Functions of Spherical Camera	Horizontal Turning	0--15° /s (constant P/T: 15° /s fixed)
	Vertical Turning	0--15° /s (constant P/T: 15° /s fixed)
	Preset Positions	64 presets (max)
	Patrol Function	At best 6 cruises

VI. Analysis of Normal Troubles

Problems	Possible Causes	Remedies
No action and images when power is switched on	Power supply damaged or insufficient power	Replace
	Wrong connection of power supply	Correct
	Faults in engineering circuits	Remove
Abnormal self-inspection. Images with roaring sound of the motor	Mechanical fault	Repair
	Tilting camera	Place uprightly
	Insufficient electrical power	Replace with qualified power supply and let it close to the spherical camera
Normal self-inspection but no images	Wrong connection of VF circuit	Correct
	Bad connection of VF circuit	Remove
	Camera damaged	Replace
Successful self-inspection but out of control	Wrong connection of control signal wire	Correct
	Mismatched address of spherical camera	Reselect
	Mismatched protocol	Adjust protocol to match with the controller and switch on again
Images unstable	Bad connection of VF circuit	Remove
	Insufficient electrical power	Replace
Dome Camera out of control	Abnormal self-inspection	Switch on again
	Bad connection of control wire	Remove
	Problems on main frame	Switch on the main frame
	Too heavy load or longer distance of communication	1. Connect 120 Ω resistor to the farthest camera and let other cameras to be broken; 2. Increase code distributor.

Normal problems and their causes and remedies mentioned above are only for reference. Should you meet other special problems, you can ask for technical support from your dealer directly.