

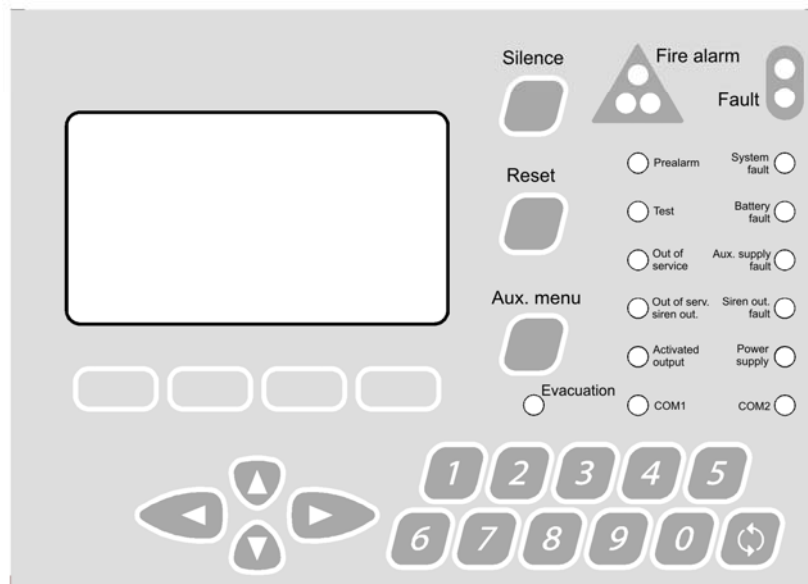

INSTALLER MANUAL

F100R REPEATER PANEL



EXCELLENT FIRE SYSTEM

INDEX

PART 1 GENERAL INFO	3
1.1 HOW TO SELECT A FUNCTION FROM THE PANEL MENU	4
1.2 PASSWORD.....	5
PART 2 INSTALLATION	6
2.1 SAFETY MEASURES	6
2.2 PLACING THE CONTAINER ON THE WALL	6
2.3 DESCRIPTION OF CLAMP CONNECTORS	6
PART 3 CONNECTION ON MINI NETWORK	8
3.1 SERIAL 1 (RS-232).....	8
3.1.1 CONNECTIONS	8
3.1.2 PROGRAMMING	8
3.1.2.1 ENABLE SERIAL 1	9
3.1.2.2 ACCESS TO SERIAL 1	9
3.1.2.3 DISABLE CONNECTION TO SERIAL 1	9
3.2 SERIAL 2 (RS-485).....	9
3.2.1 CONNECTIONS	9
3.2.2 PROGRAMMING	11
3.2.2.1 ENABLE SERIAL 2.....	11
3.2.2.2 ACCESS TO SERIAL 2	11
3.2.2.3 DISABLE CONNECTION TO SERIAL 2	11
PART 4 CONNECTION TO LOCAL NET	12
4.1 RS-485 NET	12
4.2 ETHERNET NETWORK.....	15
4.3 RS-485 / ETHERNET	17
4.4 PROGRAMMING	17
4.4.1 NETWORK ADDRESSING	17
4.4.2 REPEATER MASTER PANEL FUNCTIONS.....	17
4.4.2.1 SET-UP REPEATER MASTER PANEL.....	17
4.4.2.2 ADDING A CONTROL PANEL/REPEATER IN NETWORK	18
4.4.2.3 LISTING CONTROL PANEL/REPEATER IN NETWORK.....	18
4.4.2.4 REMOVING A CONTROL PANEL/REPEATER FROM NETWORK.....	18
4.4.3 MANAGING SUPERVISED CONTROL PANELS	18
4.4.3.1 ADDING A SUPERVISED CONTROL PANEL.....	18
4.4.3.2 PROPERTIES OF A SUPERVISED CONTROL PANEL.....	18
4.4.3.3 REMOVAL OF A SUPERVISED CONTROL PANEL.....	18
PART 5 TECHNICAL DATA	19
PART 6 NOTE DELL'INSTLLATORE.....	20

PART 1

GENERAL INFO

The repeater panel has been designed in conformity to the latest regulations bearing the following characteristics:

- The repeater panel is setup with two opto-isolated serial ports, RS-232 e RS-485.
 1. COM1 (SERIAL 1)
 - Module RS 232: Mini-network
 2. COM2 (SERIAL 2)
 - Module RS485: Mini-network, Network RS485, LAN TCP/IP

The repeater panel has two sets of clamp connectors: the top left one is for the RS-485 connections while the RS-232 host is placed on the upper right side. The power connectors are placed on the lower left section of the panel box.

The repeater panel can be connected in 2 ways: on local (RS-485, Ethernet) or on mini-network.

With the local network it is possible to interconnect up to 64 control panels which can be, in our case, either EX-RIP panels or control panels interacting by a master control unit constituted by the X-ADVISOR program installed on a computer PC based Windows '98 last version or better for minimum configuration. Through this program all control panels communicate to the computer master any fault or alarm events which pertain to zones and or points, which have been drawn up on the mapping configuration, can be seen and identified at real time during the actual progress of the message relayed.

In our case the repeater panel can serve as master so that the message will be relayed and signalled from the control panel/s which are connected.

1.1 HOW TO SELECT A FUNCTION FROM THE PANEL MENU

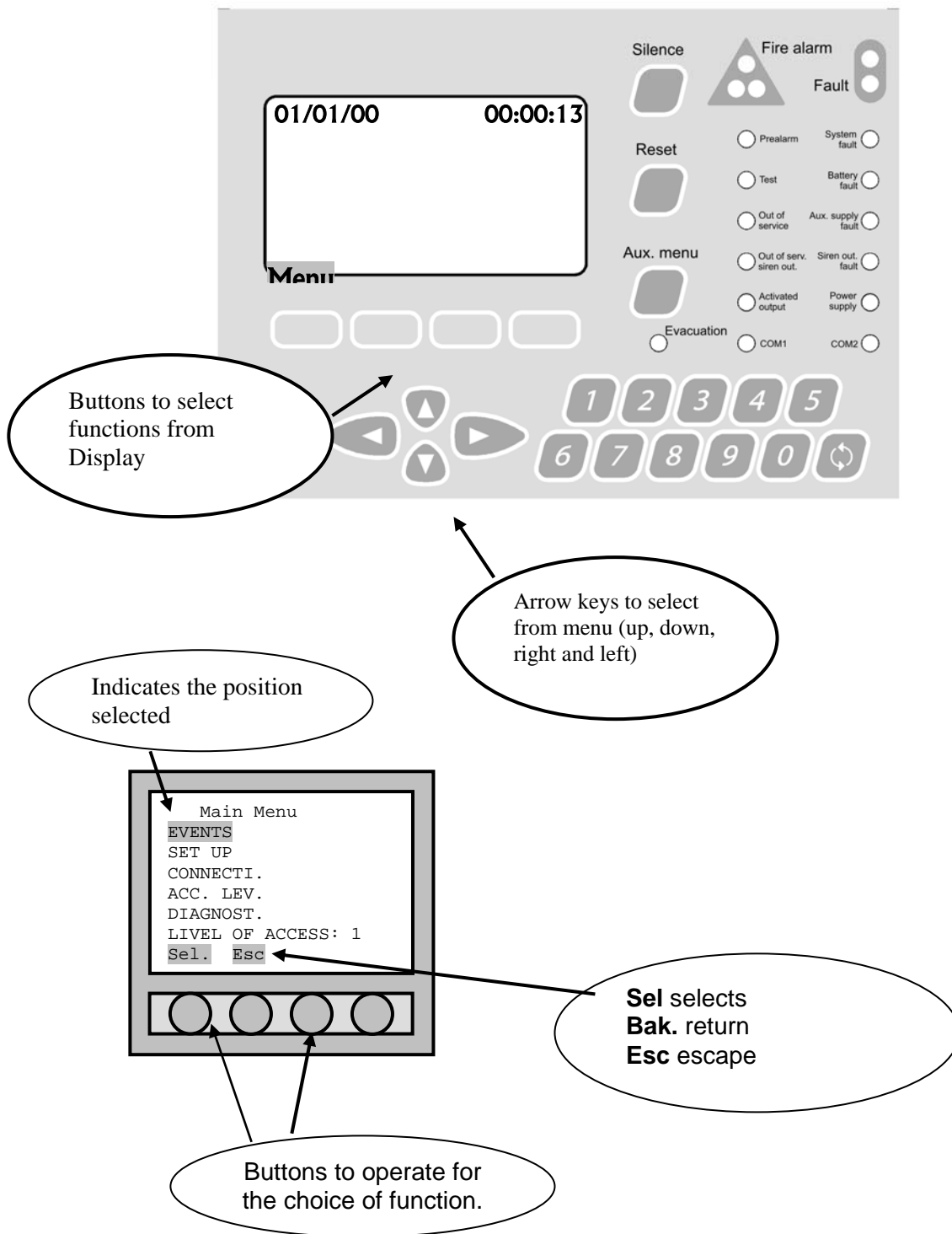

The Led signals of COM1 and COM2 (valid only on “mini-Network” mode):

- Led COM1: indicates the connection status of a control panel to RS-232 serial
- Led COM2: indicates the connection status of a control panel to RS-485 serial
- Led on permanent: control panel is properly connected.
- Led blinking: control panel connection fault (the control panel may not be connected to the serial port).
- Led off: serial port disabled for connection to a control panel.

In the “local network” mode the led COM1 and COM2 are not utilized.

1.2 PASSWORD

The repeater panel features four differentiated access levels, as expected by the EN 54-2 normative.

The request for the password is anticipated by the control panel by different displayed character symbols:

- Small caps indicate the case in which you may decide to proceed with a password;
- Capitol letters (upper case keys) indicate the case in which the user may continue without password.

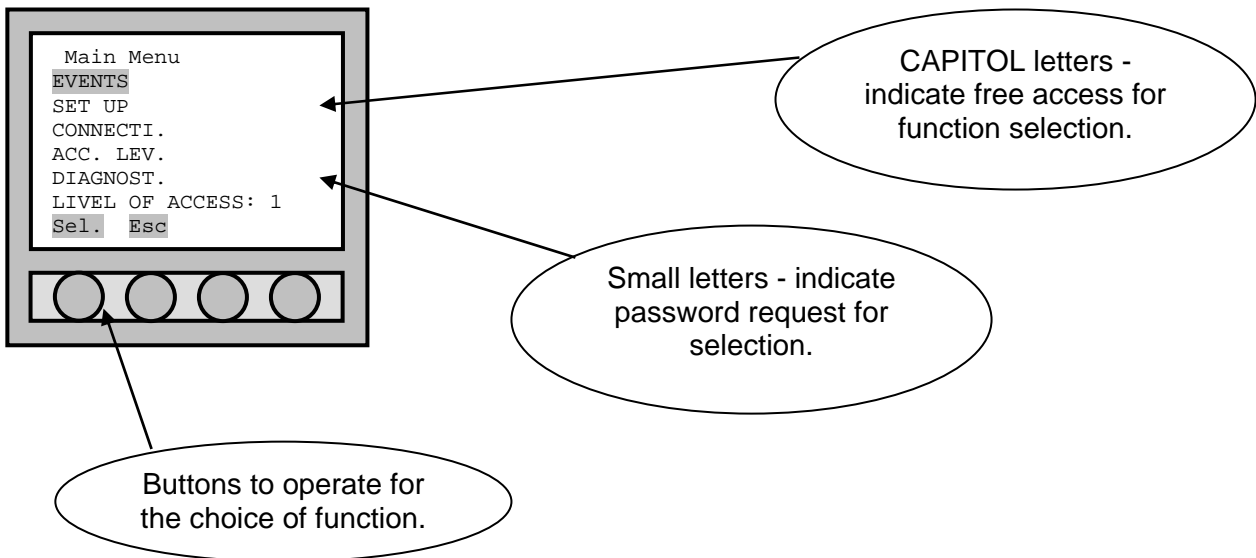

By default the passwords are:

Level 2: **22222**

Level 3: **33333**

PART 2 INSTALLATION

2.1 SAFETY MEASURES

The control panel installation must be executed by qualified personnel. Only the persons authorized may open the panel.

Where to install the product.

Place the product in a dry and covered area away from any weather agents. Do not install the product nearby any heat source or in dusty areas or places where it can come in contact with corrosive elements.

Excessive temperature and/or overheating may compromise the proper functioning and the durability of the product. Ensure that there is a proper ventilation in the area where it is installed.

Any presence of humidity such as condensation from water may cause damages. In case there is presence of condensation, please wait at least a couple of hours before operating the product and ensure that it is completely dry. If the product is stored in a cool or cold area, bring it to the area of installation and wait a couple of hours before start up to the power line.

IMPORTANT: only authorized personnel is allowed to open the product. Do not attempt to repair without authorization or else the warrantee will be void.

2.2 PLACING THE CONTAINER ON THE WALL

The repeater panel weighs about 430g. As you fix the container on the wall's vertical surface, utilize the little brackets provided upon request: these are to be fitted with the screws on the lower inferior part of the container where the closing holes are.

Precaution: the mounting procedures described in this manual are to the sole knowledge of the authorized installer/s.

2.3 DESCRIPTION OF CLAMP CONNECTORS

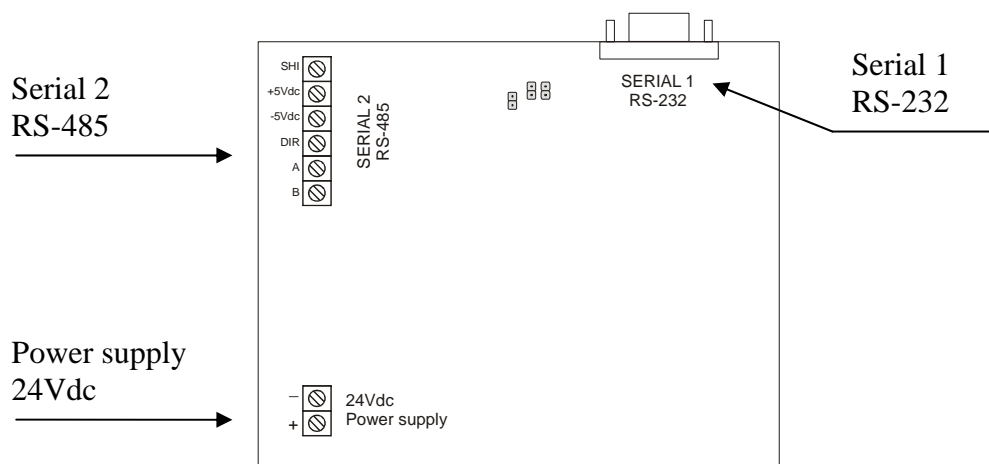

For the system cabling we must have, besides the data cable for network RS-485 o RS-232, and adequate power supply for the repeater panel. It must be power on a 24Vdc line with minimum 50mA. To power up the panel it is possible to utilize the output of the control panel that you may see from its technical manual that it can give a maximum amperage output of 315mA.

PART 3

CONNECTION ON MINI NETWORK

By means of connection to the mini network the repeater panel can manage directly 2 control panels from which one can run on the RS-232 line (control panel 1) and the other on the RS-485 line (control panel 2) so that both control panels can be piloted as they were connected to one main control keyboard.

In the reverse way, however, one control panel can interact with one repeater panel only.

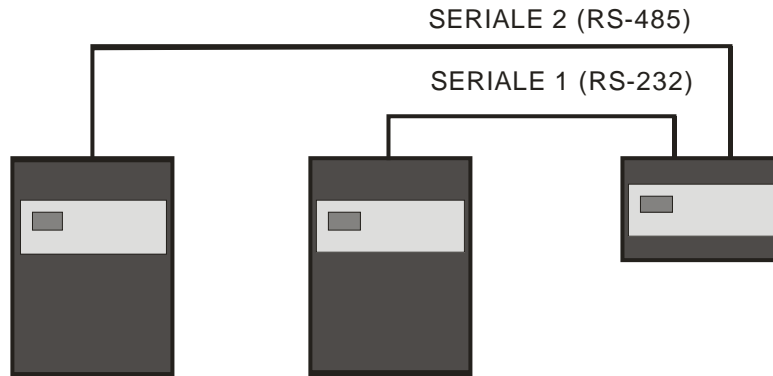

WARNING: To enable this kind of network, it is necessary to have first disabled the “local net” in RS-485. Remove all control panels connected to it and bring the address of network to 99.

For this type of connection, the button command \cup is enabled for the connection and disconnection of the repeater panel of the control panels. Once the repeater panel is programmed, it is possible to have full access to command the control panels by pressing the \cup button and proceed to the next selection of control panel. In the same way, it is possible to exit from the direct connection to the control panel by means of the same command button \cup .

3.1 SERIAL 1 (RS-232)

3.1.1 CONNECTIONS

For the RS-232 network, a male-to-male plug twisted cable must be utilized, as by figure reported – maximum length is 15m.

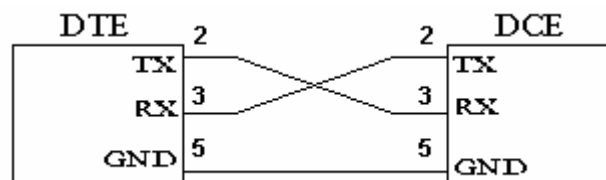

3.1.2 PROGRAMMING

WARNING: The connected control panels must have the network address 99.

From the control panel menu select:

"MENU" → "CONNECT." → "loc.net" → "NET ADDRESS:99"

3.1.2.1 ENABLE SERIAL 1

To enable the connection to serial 1 (RS-232) it is necessary to access the menu "Select serial":

"MENU" → "CONNECT." → "NET 232" → "C.PAN.CON." → "SERIAL 1"

3.1.2.2 ACCESS TO SERIAL 1

This function allows to access the menu of the control panel which is connected to the serial 1 directly from the repeater panel.

"MENU" → "CONNECT." → "NET 232" → "LINK PAN." → "CON.PANEL 1"

WARNING: to return to menu of the repeater panel you must press the special button:  and the "Del" key.

3.1.2.3 DISABLE CONNECTION TO SERIAL 1

This function allows to disable the connection from serial 1.

"MENU" → "CONNECT." → "RETE 232" → "DISC.PAN." → "CON.PANEL 1"

3.2 SERIAL 2 (RS-485)

3.2.1 CONNECTIONS

For the RS-485 net it is necessary to adopt a type of cable according to the length and possible expected ambient disturbances. The technical table below illustrates the parameters for the selection of cable:

TYPE CONNECTION	PRESENCE OF AMBIENT DISTURBANCE	LENGHT OF NETWORK [m]	TWIISTED CABLE	SHIELDED CABLE	CABLE SECTION/SIZE [mm ²]	N° CONDUCTORS
Connection 1	NO	from 0 to 300	NO	NO	0,5	2
Connection 2	YES	from 0 to 300	NO	YES	0,5	2
Connection 3	NO	from 300 to 1200	YES	YES	1	2
Connection 4	YES	from 300 to 1200	YES	YES	1	3

The cable to use for the network is for data transmission therefore, we recommend UTP cable or even better the S-UTP; please consult the technical manual for the RS-485 network for the type of cable to adopt for cabling lengths superior to 300m.

The RS-485 network must be connected to the control panel through the proper module of the COM1 or COM2.

CONNECTION 1

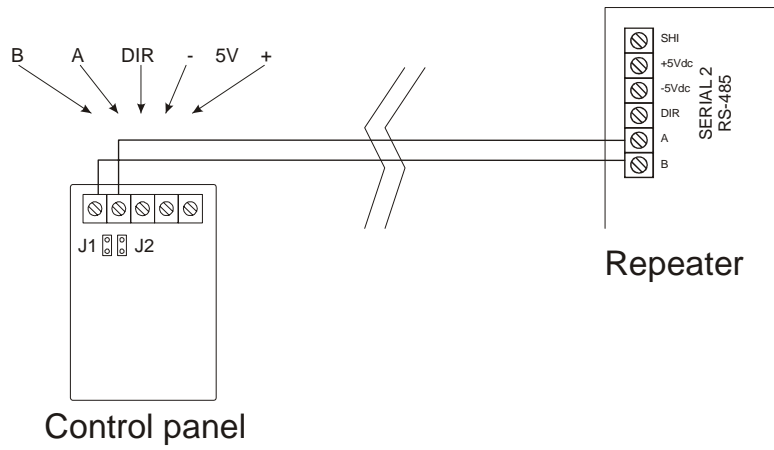

CONNECTION 2

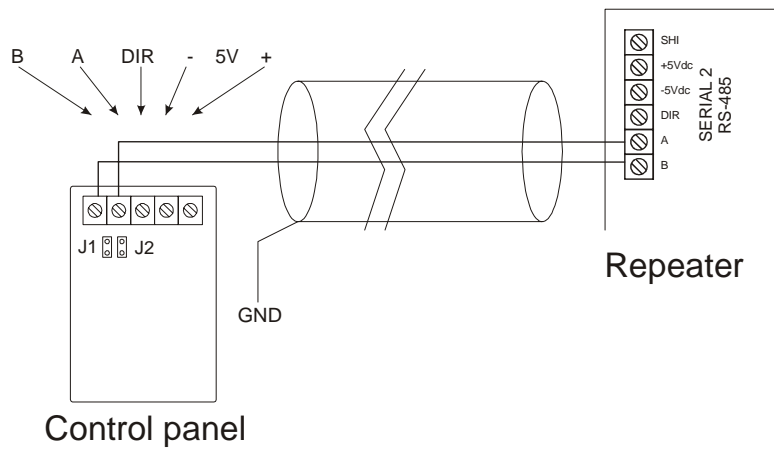

CONNECTION 3

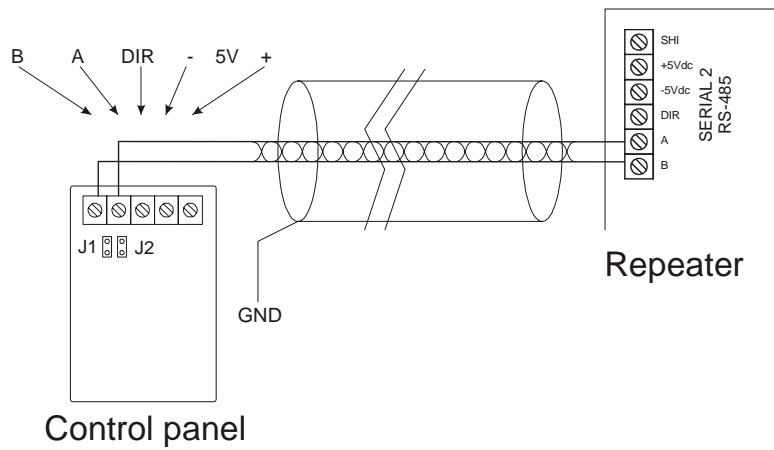

CONNECTION 4

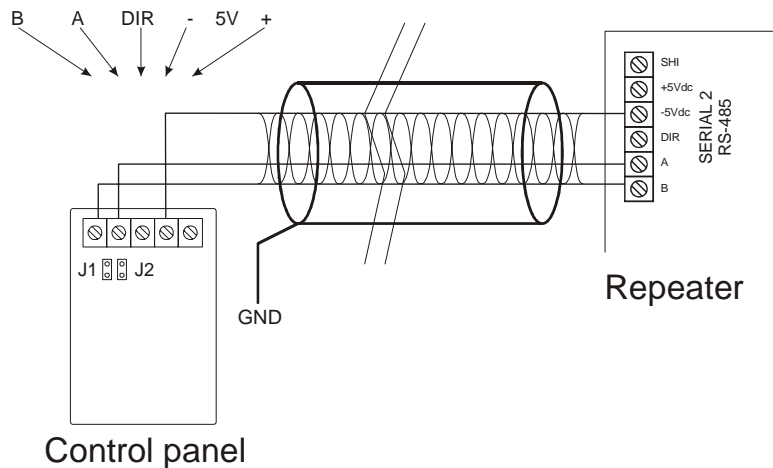

3.2.2 PROGRAMMING

WARNING: to enable this type of network, you must first disable the “Local Network” in RS-485. Disconnect all the control panels which are in the network and bring the net address back to 99.

3.2.2.1 ENABLE SERIAL 2

To enable connection to the serial 2 (RS-485) one must access the menu voice “Select serial”:

“MENU” → “CONNECT.” → “NET 232” → “C.PAN.CON.” → “SERIAL 2”

3.2.2.2 ACCESS TO SERIAL 2

This function allows to access the menu of the control panel which is connected to the serial 2 directly from the repeater panel.

“MENU” → “CONNECT.” → “NET 232” → “LINK PAN.” → “CON.PANEL 2”

WARNING: to return to menu of the repeater panel you must press the special button: ⤴ and the “Del” key.

3.2.2.3 DISABLE CONNECTION TO SERIAL 2

This function allows to disconnect from serial 2.

“MENU” → “CONNECT.” → “NET 232” → “DISC.PAN.” → “CON.PANEL 2”

WARNING: To choose which control panel to visualize; press the ⤴ button and select from the list on display.

PART 4 CONNECTION TO LOCAL NET

In the “Local Net” mode, it is possible to install several control panels and repeater panels up to a maximum total of 64 units. This system configuration expects a master to manage the net; a repeater panel can be utilized or a PC with the extra possibility to configure graphic area and points maps.

The types of nets can be:

- RS-485 (one transmission cable which connects all control panels/repeaters on the net).
- ETHERNET (every control panel or repeater is connected to the ETHERNET through an interface module in RS-232 - TCP/IP or RS-485 – TCP/IP).
- RS-485 / ETHERNET (this is a type of interconnection network which unites both RS485 and net on TCP/IP).

Whenever the ETHERNET is adopted, the net master must necessarily be on the PC with the X-Advisor software (this software is necessary for the graphic maps management).

WARNING: the enable the “Local Net”, you must first disable the “Mini net”. Remove and disconnect both serial 1 and 2. See sections 3.1.2.3 and 3.2.2.3.

4.1 RS-485 NET

The RS-485 network is composed of a single line for transmission (without extra sub-lines) from which the control panels are connected. As well as for the repeater panels and the net master.

For the RS-485 network you must utilize a type of cable depending on the length of the entire course and the possible disturbances which could occur. The chart below illustrates a reference for the parameters to follow:

TYPE CONNECTION	PRESENCE OF AMBIENT DISTURBANCE	LENGHT OF THE NETWORK [mt]	TWISTED CABLE	SHIELDED CABLE	CABLE SECTION / SIZE [mm ²]	N° CONDUCTORS
Connection 1	NO	from 0 to 300	NO	NO	0,5	2
Connection 2	YES	from 0 to 300	NO	YES	0,5	2
Connection 3	NO	from 300 to 1200	YES	YES	1	2
Connection 4	YES	from 300 to 1200	YES	YES	1	3

The cable to use for the network is for data transmission therefore, we recommend UTP cable or even better the S-UTP; please consult the technical manual for the RS-485 network for the type of cable to adopt for cabling lengths superior to 300m.

The RS-485 network must be connected to the control panel through the proper module of the COM1 or COM2.

WARNING: for the sake of safety and network stability, it is advisable to protect all devices which are 230Vac operated from power outage or surges; provide with an auxiliary power supply back-up unit.

CONNECTION 1

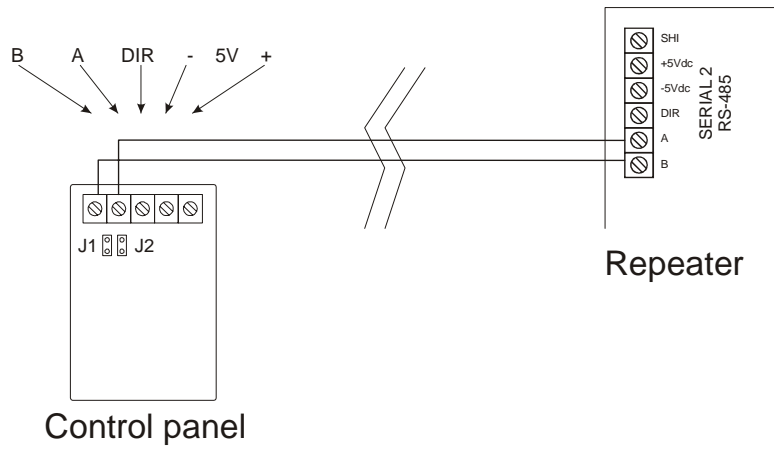

CONNECTION 2

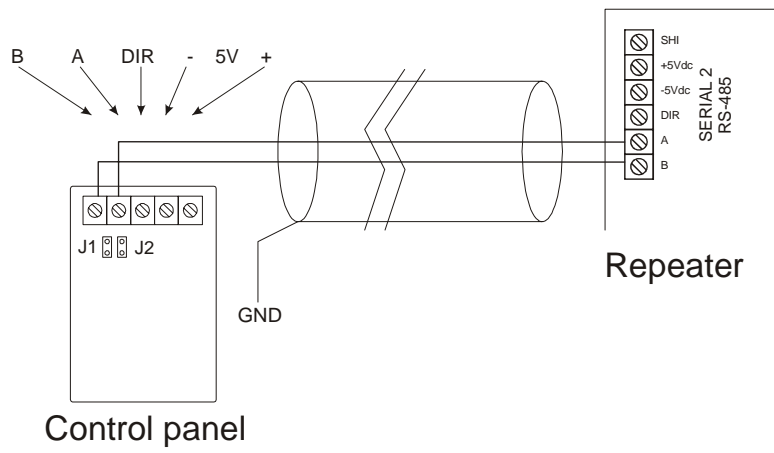

CONNECTION 3

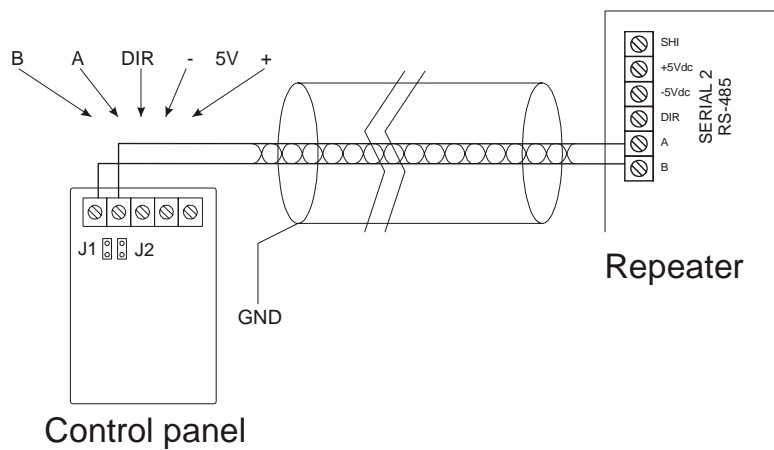

CONNECTION 4

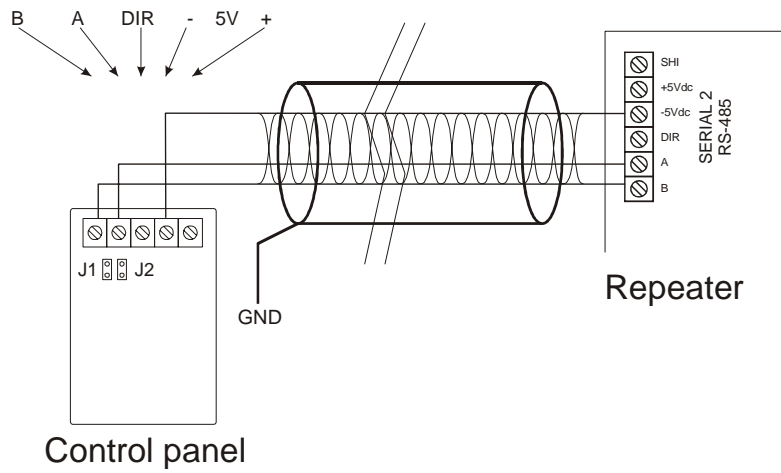

(Example of Schematics) LOCAL- NET CONNECTION TO (PC MASTER)

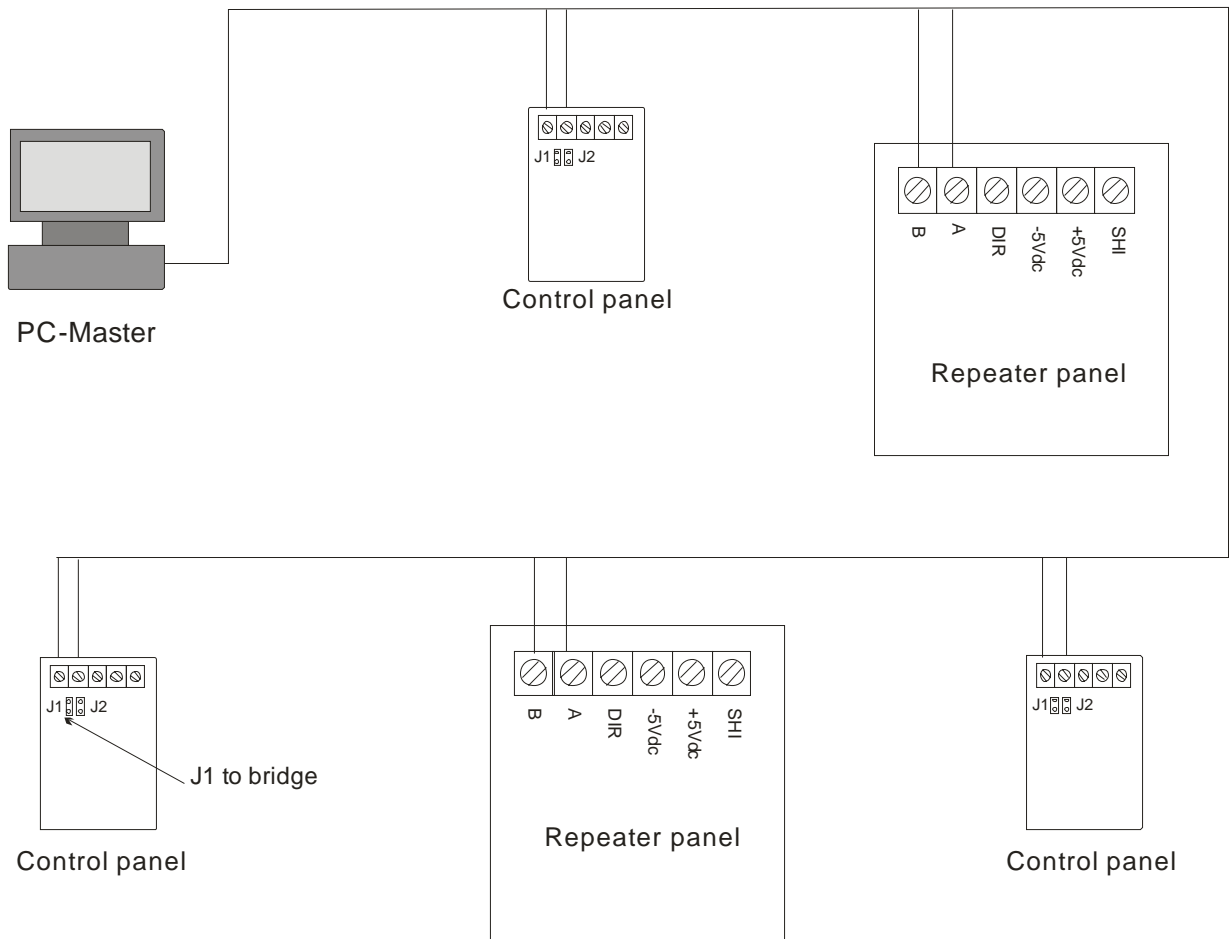

(Example of Schematics) CONNECTION IN LOCAL- NET TO (REPEATER PANEL MASTER)

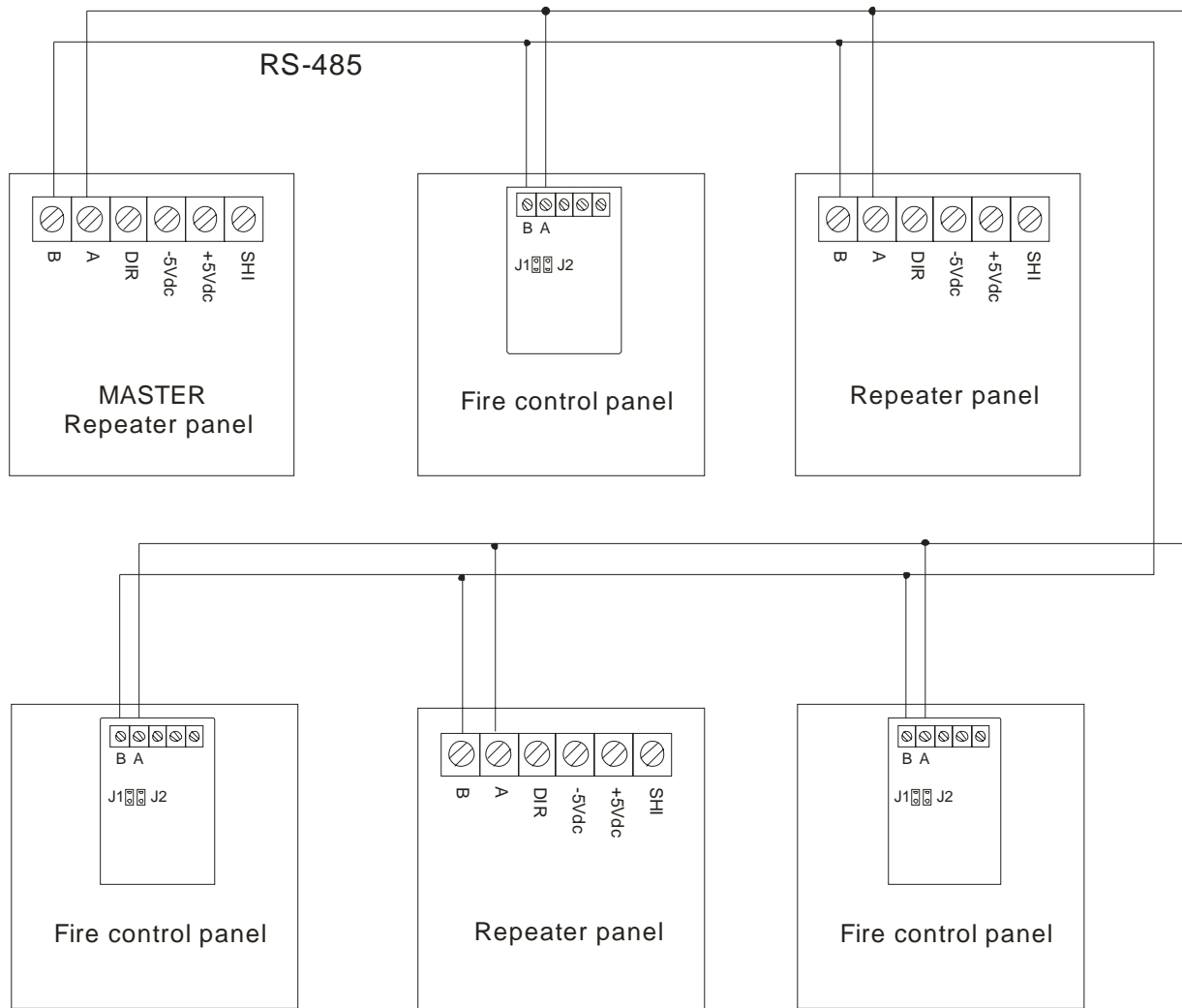

WARNING: In the case that cable shielding is needed, for installation disturbances related to ambient or cable extra lengths, just bring out the cable sheath to one side of the terminal for the round wiring (do this cable adjustment on the side of the network which carries more devices).

4.2 ETHERNET NETWORK

The ETHERNET network is made up of a group of crossover points (switch) by which the control panels and repeaters are interconnected. Control panels and repeaters do not have Ethernet ports built-in therefore, they need the interface devices of RS-232 or RS-485 in TCP/IP.

WARNING: to ensure safety and network line stability, we recommend to create a dedicated Ethernet network by avoiding the PC, router and other devices which are not necessary for the network line. In addition, for the sake of safety and network stability, it is advisable to protect all devices which are 230Vac operated from power outage or surges; provide with an auxiliary power supply back-up unit.

CONNECTION CONFIGURATION (EXAMPLE)

As an interface device between control panels or repeater panels and the TCP/IP net, it is advisable to adopt the module MOXA – NPort DE-211. In attachment to the CD of the control panel a file is supplied for the configuration (“SetupMoxaDE-211.txt”) so you may automatically acquire the module’s set-up; software for the MOXA is the “NPort Management Suite” which comes with the module itself.

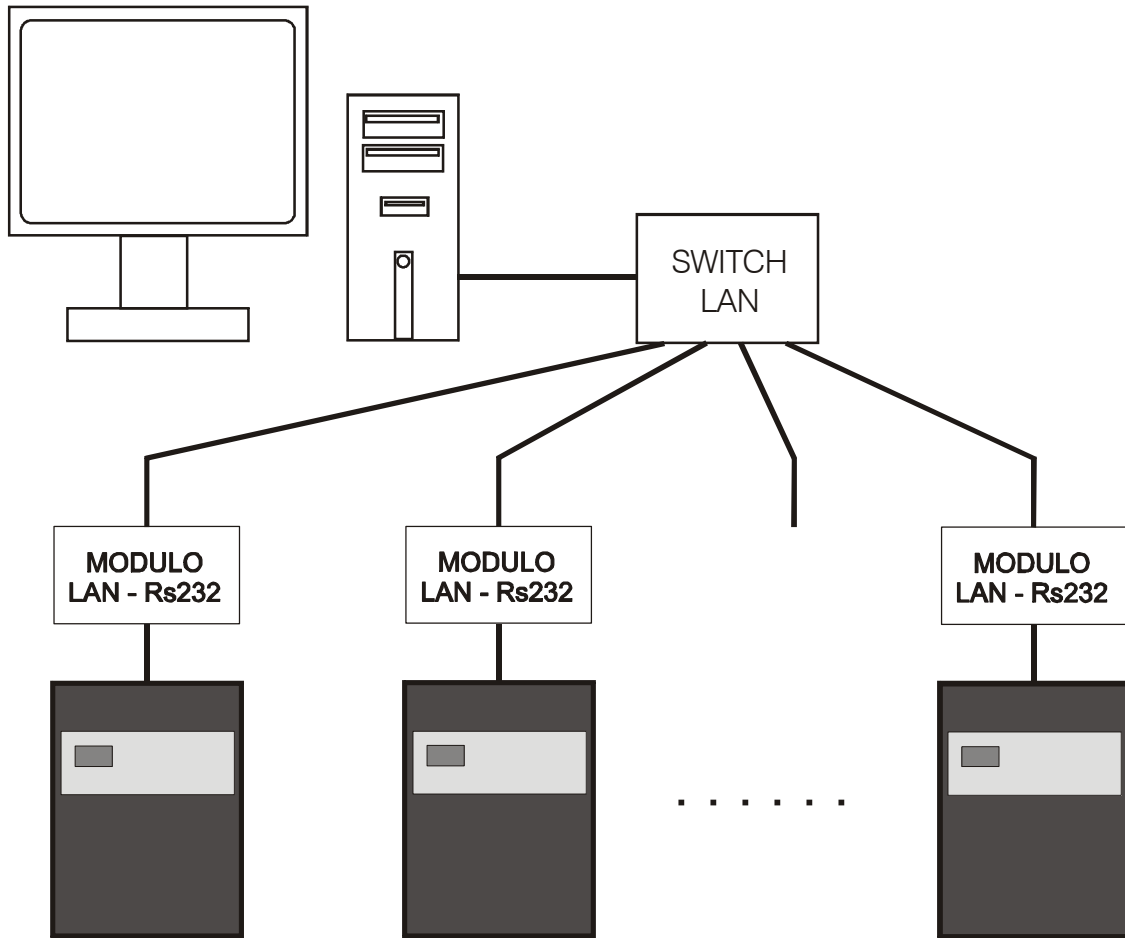

The interface modules TCP/IP with which the control panels or repeaters can be set-up are the following:

NetWork setting:

- IP Address: 192.168.xxx.yyy
- Netmask: 255.255.255.000
- IP Configuration: Static IP

OP Mode:

- OP Mode: TCP Server

Serial Setting:

- Baud rate: 9600
- Parity: Even
- Data Bits: 8
- Stop Bit: 1
- Flow Control: None
- UART FIFO: Enable

4.3 RS-485 / ETHERNET

This type of net is an hybrid between the Ethernet network and the RS-485. The main interconnection point is in dialogue with the network master (PC) and it is a switch type. To this type of network the interface modules for the RS-232 and RS-485 lines are connected to line up of the control panels and repeaters. If on one RS-232 line just one control panel (or repeater) can be connected, then on a RS-485 line you may connect more control panels and/or repeaters (by following the instruction on section 4.1).

WARNING: due to the complexity of the system, it is necessary to respect the indications described on sections 4.1 and 4.2.

4.4 PROGRAMMING

WARNING: to enable this type of network, it necessary to first disable the "232 Net". See sections 3.1.2.3 and 3.2.2.3).

4.4.1 NETWORK ADDRESSING

As first step it is necessary to assign the net address.

"MENU" → "CONNECT." → "LOC. NET." → "options" → "ADDRS.NET: 99"

With address 99 the "local net" connection is disabled.

4.4.2 REPEATER MASTER PANEL FUNCTIONS

The "Local Net" to operate needs to have a master in the network. On a network you can have more master panels (for example the PC and a repeater panel) so you must know which one you want to serve as master.

Should you choose the have the repeater panel as master of the network you must do the following:

1. Enable the master function of the repeater panel;
2. Insert in the master database the addresses of the control panels and of the repeater which constitute the network.

Nonetheless, no matter whether you enable the master function or not, the repeater panel may work as supervisor of the control panels (see section 4.4.3).

4.4.2.1 SET-UP REPEATER MASTER PANEL

To enable the panel as the MASTER it is necessary to initialize the following functions:

"MENU" → "CONNECT." → "LOC.NET." → "options" → "NETWORK MASTER:"

Select "Yes" to enable or "No" to disable the MASTER function.

WARNING: to disable the MASTER function it is necessary to remove the addresses to all the repeater and control panels connected to network. On the contrary it isn't possible to disable the MASTER function.

4.4.2.2 ADDING A CONTROL PANEL/REPEATER IN NETWORK

To program the local net based on the repeater MASTER panel it is necessary to insert the address of all or any control panels and repeaters connected to network.

To install a device, it is necessary to have it connected before to the local net and switch it on.

Access the menu "NET AVAIL." and select "add" to insert the address.

"MENU" → "CONNECT." → "LOC.NET" → "NET DEVIC." → "ADD"

The master panel will search for the new added address in the net to verify its presence; if found, it confirms the address acquisition.

4.4.2.3 LISTING CONTROL PANEL/REPEATER IN NETWORK

Access to menu "view" to verify the devices connected to the local net.

"MENU" → "CONNECT." → "LOC.NET" → "NET DEVIC." → "VIEW"

4.4.2.4 REMOVING A CONTROL PANEL/REPEATER FROM NETWORK

Access the menu "remove" to take away a device from the database of the master repeater panel connected to local net.

"MENU" → "CONNECT." → "LOC.NET" → "NET DEVIC." → "REMOVE"

4.4.3 MANAGING SUPERVISED CONTROL PANELS

Every repeater panel connected to the net can supervise up to a total 8 control panels. The repeater panel filters the events which transit on the net as they are acquired/elaborated the ones for which it is programmed for.

4.4.3.1 ADDING A SUPERVISED CONTROL PANEL

With the repeater panel properly connected to network (no fault signal) it is possible to add to the database the control panels you wish to supervise.

"MENU" → "CONNECT." → "LOC.NET" → "CON. PAN." → "ADD"

The control panel address is requested and successively the net polling is performed. Once the control panel is found in the net, it is added to the database of the repeater panel.

4.4.3.2 PROPERTIES OF A SUPERVISED CONTROL PANEL

Every control panel can filter the type of event to monitor (alarms, faults,...). Moreover, it is possible to select a range of zones to supervise (all of them are already set-up by default).

From the option "remote control" it is possible to restore the control panel once the repeater panel is restored.

4.4.3.3 REMOVAL OF A SUPERVISED CONTROL PANEL

To remove a control panel from the database of the repeater panel it is necessary to perform the following action:

"MENU" → "CONNECT." → "LOC.NET" → "CON. PAN." → "REMOVE"

The control panel address is requested and successively you may proceed with the remove operation.

PART 5 TECHNICAL DATA

GENERAL

Container dimensions:	B x L x H 189x62x137mm.
Material of container:	ABS black
Mounting:	Desk top – horizontal position. On the wall – vertical position.
IP (protection index):	IP20.
Weight:	430g
Operating temperature:	- 5 + 40°C.
Relative humidity:	< 95% relative humidity, not condensation.
Cleaning front panel:	It is possible to clean the front panel/display with a damp cloth. Do not use any chemical base detergents.
Power absorb in Stand-By:	< 10mA.
Max Current:	50mA.
Power supply:	da 20Vdc a 29Vdc
Connections:	SERIAL 1: RS-232 with “female” connector a 9pin external collector; SERIAL 2 RS-485 internal connector clamps.
Max connection length	SERIAL 1: RS-232: 15m SERIAL 2 RS-485: 1200m

